

Hive Assembly - Roof

National, Langstroth, Dadant, Smith, Commercial

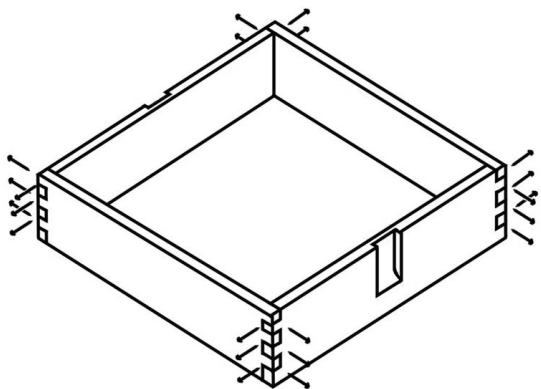

1. Glue and nail together the four side walls with the vents opposite each other facing out, using 1.5" nails.

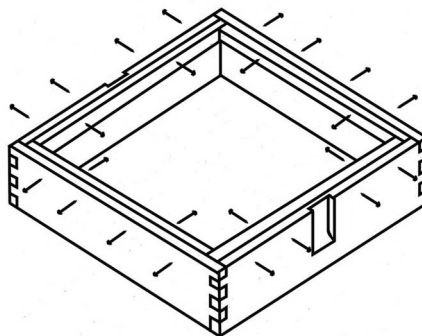

2. Glue and nail the four head space laths around inside of roof, flush with top of the side walls, using 1" nails.

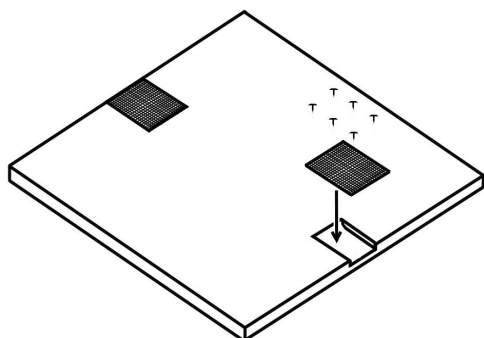

3. Check roof is square. Using drawing pins, pin the ventilator mesh over slots in top board.

(Note: for the Budget roof, the top board may be made up of several pieces)

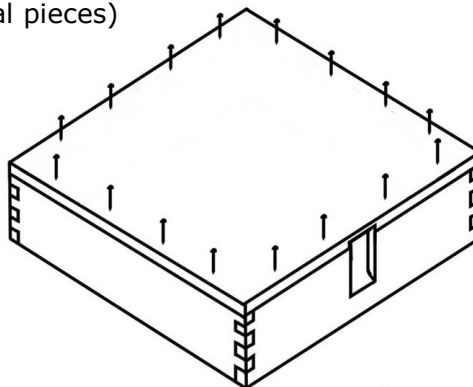

4. Turn top board over and glue and nail to the frame created, using 1" nails, ensuring board vents line up with vents in side walls.

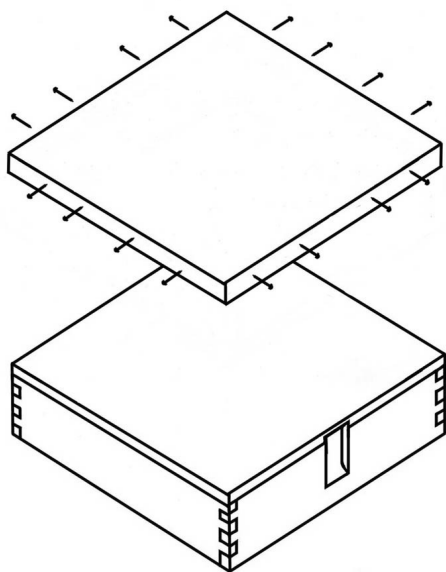

5. Place metal over boards and nail along the sides, using 1" nails.
(The metal may require the use of a bradawl)

THORNE

E.H. THORNE (Beehives) LTD

Beehive Business Park, Rand, Nr. Wragby, Lincolnshire LN8 5NJ

Tel: 01673 858555

Fax: 01673 857004

sales@thorne.co.uk

www.thorne.co.uk